

Introduction

This Technical Booklet has been prepared by the Department of Finance and Personnel and provides for certain methods and standards of building which, if followed, will satisfy the requirements of the Building Regulations (Northern Ireland) 2000 ("the Building Regulations").

There is no obligation to follow the methods or comply with the standards set out in this Technical Booklet.

If you prefer you may adopt another way of meeting the requirements of the Building Regulations but you will have to demonstrate that you have satisfied those requirements by other means.

Other regulations

This Technical Booklet relates only to the requirements of H3, H4, H5, H6 and H7. The work will also have to comply with all other relevant Building Regulations.

British Standards and European Technical Specifications

In this introduction and throughout this Technical Booklet any reference to a British Standard shall be construed as a reference to –

- (a) a British Standard or British Standard Code of Practice;
- (b) a harmonised standard or other relevant standard of a national standards body of any Member State of the European Economic Area;
- (c) an international standard recognised for use in any Member State of the European Economic Area;
- (d) any appropriate, traditional procedure of manufacture of a Member State of the European Economic Area which has a technical description sufficiently detailed to permit an assessment of the goods or materials for the use specified; or
- (e) a European Technical Approval issued in accordance with the Construction Products Directive,

provided that the proposed standard, code of practice, specification, technical description or European Technical Approval provides, in use, equivalent levels of safety, suitability and fitness for purpose as that provided by the British Standard.

Products conforming with a European Council Directive

Any product designed and manufactured to comply with the requirements of a European Council Directive does not have to comply with any other standard or part of a standard, whether British, International or other, which relates to the same characteristic or specific purpose as the EC Directive.

CE marked construction products

Any construction product (within the meaning of the Construction Products Directive) which bears a CE marking shall be treated as if it satisfied the requirements of any appropriate British Board of Agrément Certificate, British Standard or British Standard Code of Practice relating to such a product, where the CE marking relates to the same characteristic or specific purpose as the Certificate, Standard or Code of Practice.

Testing of materials and construction

Where for the purposes of this Technical Booklet testing is carried out it shall be carried out by an appropriate organisation offering suitable and satisfactory evidence of technical and professional competence and independence. This condition shall be satisfied where the testing organisation is accredited in a Member State of the European Economic Area in accordance with the relevant parts of the EN 45000 series of standards for the tests carried out.

Materials and workmanship

Any work to which a requirement of the Building Regulations applies must, in accordance with Part B of the Building Regulations, be carried out with suitable materials and in a workmanlike manner. The requirements of Part B can be complied with by following an appropriate British Standard or it may be demonstrated that the requirements have been complied with by other suitable means, such as an acceptable British Board of Agrément Certificate, Quality Assurance Scheme, Independent Certification Scheme or Accredited Laboratory Test Certificate.

Diagrams

The diagrams in this Technical Booklet supplement the text. They do not show all the details of construction and are not intended to illustrate compliance with any other requirement of the Building Regulations. They are not necessarily to scale and should not be used as working details.

References

Any reference in this Technical Booklet to a publication shall, unless otherwise stated, be construed as a reference to the edition quoted, together with any amendments, supplements or addenda thereto current at 22 November 2000.

Contents

	Page
Section 1 General	3
Section 2 Stairs	4
Section 3 Ramps	8
Section 4 Guarding	9
Section 5 Vehicle loading bays	11
Section 6 Protection against impact from and trapping by doors	12
Section 7 Protection from collision with open windows, skylights or ventilators	13
Appendix Publications referred to	14

Section 1 – General

1.1 Part H does not require a building, other than a dwelling of more than one storey, to have a stair. However, where a stair or ramp is provided it must comply with the requirements of Part H.

A stair or ramp which forms part of a means of access for disabled people as required by Part R, or part of a means of escape in the case of fire as required by Part E, may need to meet requirements in those parts which are additional to the provisions described in this Part.

Definitions

1.2 In this Technical Booklet the following definitions apply –

Assembly building – place of assembly, entertainment or recreation, including bingo halls, broadcasting, recording and film studios open to the public, casinos, dance halls; entertainment, conference, exhibition and leisure centres; funfairs and amusement arcades; museums and art galleries; non-residential clubs, theatres, cinemas and concert halls; educational establishments, dancing schools, gymnasia, swimming pool buildings, riding schools, skating rinks, sports pavilions, sports stadia; law courts; churches and other buildings for worship, crematoria; libraries open to the public, non-residential day centres, clinics, health centres and surgeries; passenger stations and termini for air, rail, road or sea travel; public toilets; zoos and menageries.

Going (in relation to a step) – the depth of the tread less any overlap with the next tread (see Diagram 1.1).

Institutional building – hospital, nursing home, home for old people or for children, school or other similar establishment used as living accommodation or for the treatment, care or maintenance of people suffering from illness or mental or physical disability or handicap, place of detention, where such people sleep on the premises.

Private stair – a stair in or intended to be used by only one dwelling.

Retail building – shop, department store, supermarket, public house, restaurant with or without assembly area, cafe, hairdresser, wholesale self-selection trading, public area of a bank, building society, betting shop.

Rise (in relation to a step) – the height, including the thickness of the tread (see Diagram 1.1).

Small room – any room having a floor area not exceeding –

- (a) 4 m² in the case of a dwelling; or
- (b) 30 m² in any other case.

Step – does not include any threshold which has a height not exceeding 40 mm in the case of an internal doorway or 75 mm in the case of an external doorway.

Tapered tread – a tread which has a greater width at one side than at the other and a going which changes at a constant rate throughout its length.

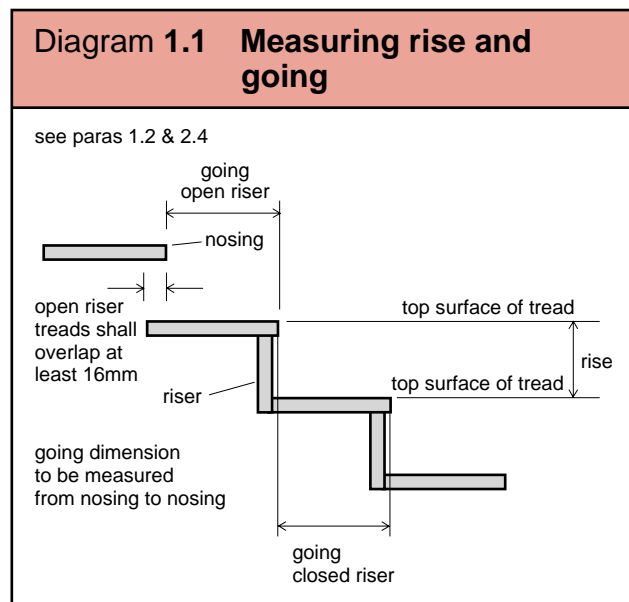

Section 2 – Stairs

Pitch

2.1 The pitch of a flight shall be controlled by limiting the rise and the going.

Diagram 2.1 shows how the pitch shall be measured and what is meant by the pitch line.

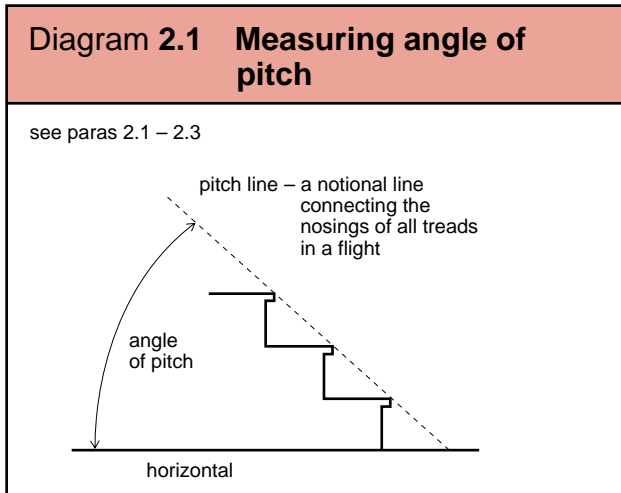

2.2 Subject to paragraph 2.3 the relationship between the dimensions of the rise and going is that twice the rise (R) plus the going (G) i.e. $(2R + G)$ shall be between 550 mm and 700 mm. The rise of each step shall not be greater, nor the going less, than the figures given in Table 2.1 and in no case shall the rise be less than 75 mm.

2.3 The pitch of a private stair shall not exceed 42° , therefore it is not possible in this case to combine a maximum rise with a minimum going.

2.4 In a flight, the steps shall all have the same rise and they shall all have the same going. Diagram 1.1 shows how to measure the rise and going (for steps with tapered treads see also paragraphs 2.17 - 2.20).

2.5 Where the landing of a stair is formed by the ground and slopes across the width of the flight, then the rise of the step shall be measured at the mid-point of the width of the flight (see paragraph 2.16).

Table 2.1 Rise and going

Category	Rise (max) (mm)	Going (min) (mm)
1 Private stair	220	220
2 A stair in or serving –		
(a) an institutional building or compartment (unless it will only be used by staff)	180	280
(b) an assembly building or compartment and serving an area used for assembly purposes (unless the area is less than 100m^2)	180	280
(c) the mall of a shopping centre	180	280
3 A stair not described in 1 or 2 above	190	250

Note

A stair within more than one category shall be constructed to the more onerous standard.

Construction of steps

2.6 Steps shall have level treads which extend for the full width of the flight.

Steps may have open rises, but the treads shall then overlap each other by at least 16 mm.

2.7 All stairs which have open rises and are likely to be used by children under 5 years of age shall be constructed so that a 100 mm diameter sphere cannot pass through the open rises.

Headroom

2.8 Stairs shall have a clear headroom of not less than 2 m over their full length and width.

Headroom is measured vertically from the pitch line of the flight and the level of the landing (see Diagram 2.2).

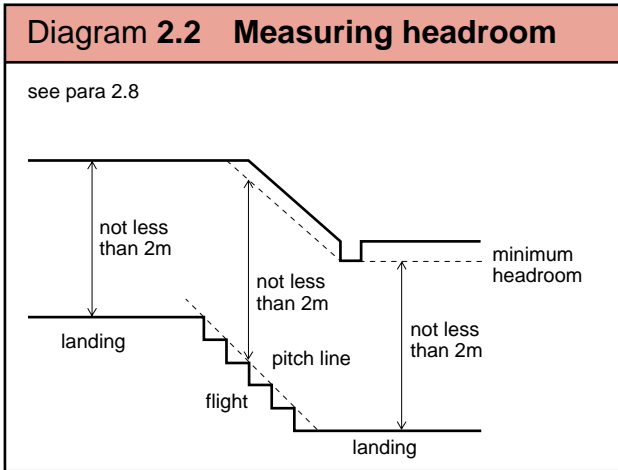

Width of flights

2.9 The minimum unobstructed widths for flights are given in Table 2.2 and shall be measured in accordance with Diagram 2.3.

Table 2.2 Widths of flights

Category	Unobstructed width (mm)
1 Private stair –	
(a) providing access to one room only (not being a kitchen or living room) or to a bathroom and a water closet	600
(b) other than (a) above	800
2 A stair in or serving an institutional building or compartment (unless it will only be used by staff)	1000
3 A stair not described in 1 or 2 above, serving an area –	
(a) less than 100m ²	800
(b) 100m ² or more	1000

Note

A stair within more than one category shall be constructed to the more onerous standard.

Diagram 2.3 Measuring width of flights, landings and ramps

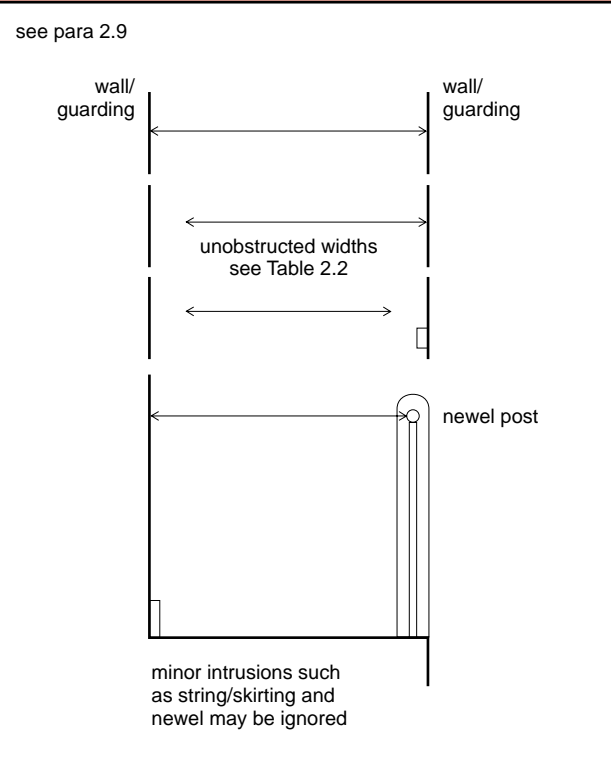

2.10 A flight, other than in a private stair, which is wider than 1800 mm shall be divided into flights which are not wider than 1800 mm (see Diagram 2.4). The minimum widths in Table 2.2 then apply to each flight.

Diagram 2.4 Dividing flights

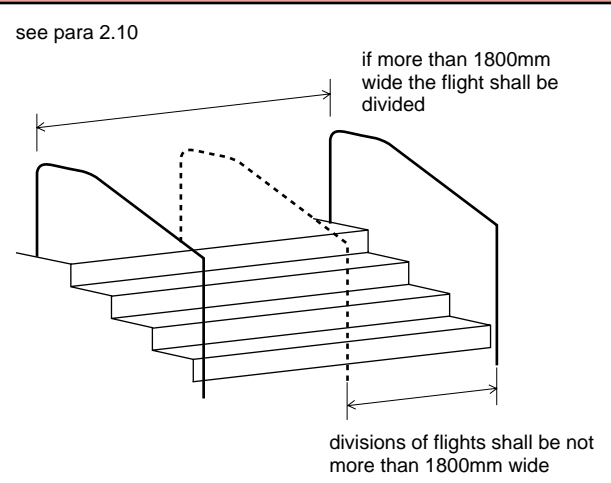

Length of flights

2.11 The number of rises in a flight shall be a maximum of 16 and a minimum of 2 in a private stair and a minimum of 3 in any other stair. However, notwithstanding the provisions of paragraph 2.15, a single step may be provided –

- (a) at the bottom of a stair in a dwelling;
- (b) at an entrance to a building;
- (c) between any enclosed porch, outhouse or conservatory and the remainder of a dwelling;
- (d) where it provides access to a shop window, small room or dais; and
- (e) between a garage and a dwelling.

2.12 Stairs of more than 36 rises in consecutive flights shall have at least one change in direction between flights of at least 30° (see Diagram 2.5).

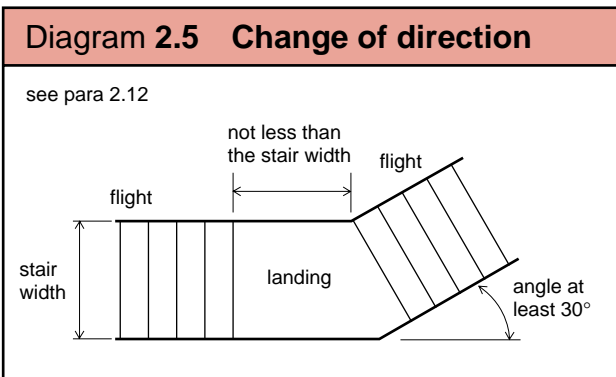

Landings

2.13 Landings shall be provided at the top and bottom of every flight.

The width of a landing shall be not less than the width of the stair.

The going of a landing shall be not less than the width of the flight.

Part of a floor may be considered as a landing.

2.14 Landings shall be clear of any obstruction. A door may swing across a landing at the bottom of a flight but only where it will leave a clear space of at least 400 mm across the full width of the flight (see Diagram 2.6).

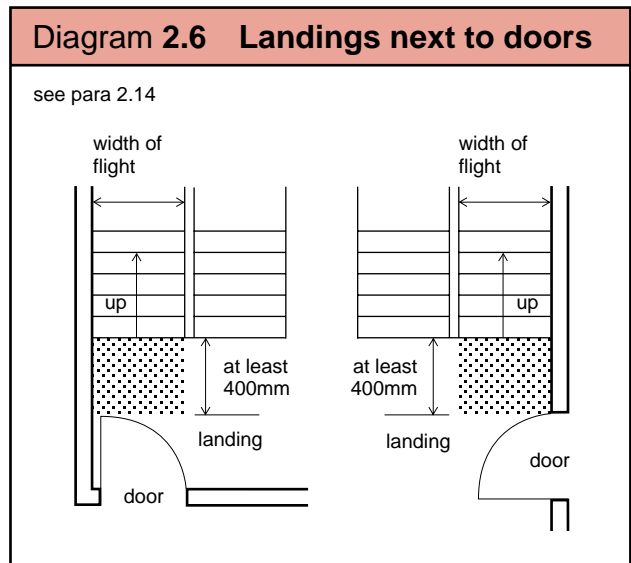

A door to a cupboard or duct may swing across a landing at –

- (a) the bottom of a flight; and
- (b) the top of a flight where it will leave a clear space of 400 mm across the full width of the flight (see Diagram 2.7).

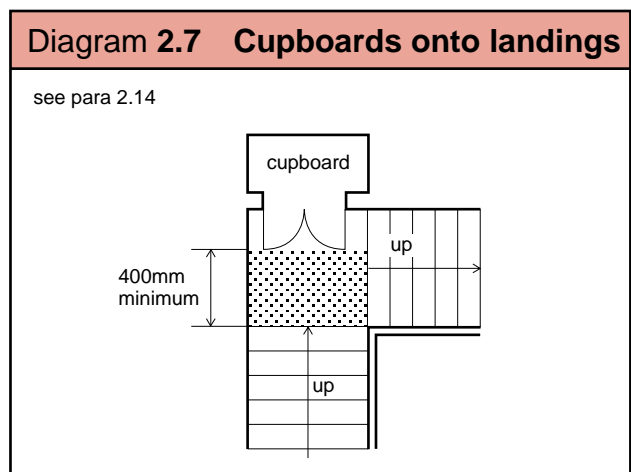

2.15 A landing need not be provided between an external flight and a doorway if the rise of the flight is not more than 600 mm and the door slides or opens away from the steps.

2.16 Landings shall be level unless they are formed by the ground at the top or bottom of a flight where they may then slope at up to 1 in 20. Landings formed by the ground shall be paved or otherwise made firm.

Steps with tapered treads

2.17 Where steps have tapered treads, the going shall be measured as follows –

- (a) if the width of the flight is less than 1 m, measure in the middle; or
- (b) if the width of the flight is 1 m or more, measure 270 mm from each side (see Diagram 2.8).

2.18 The narrow ends of consecutive treads shall be on the same side of the stair and have a going of not less than 50 mm.

2.19 The rise and the going measured at the positions, in paragraph 2.17 (a) or (b) whichever is appropriate shall be within the limits given in paragraphs 2.2 and 2.3 and Table 2.1.

2.20 Where a stair consists of straight and tapered treads, the going of the tapered treads shall be not less than the going of the treads on the straight flight.

Handrails

2.21 Flights with a total rise of more than 600 mm shall have a continuous handrail –

- (a) on at least one side where they are 1 m wide or less;
- (b) on both sides where they are more than 1 m wide; or
- (c) on both sides where a stair is divided into adjacent flights in accordance with paragraph 2.10.

Where only one handrail is required on a flight with tapered treads, it shall be located on the outer side of the flight.

2.22 Handrails are not required –

- (a) beside the two steps at the bottom of a stair (except in a public building); or
- (b) where the side of a flight is formed by fixed seating.

2.23 Handrails shall be at a height measured vertically of between 900 mm and 1 m above the pitch line, give firm support and allow a firm grip.

Handrails may form the top of guarding.

Diagram 2.8 Measuring tapered treads

see paras 2.17 – 2.19

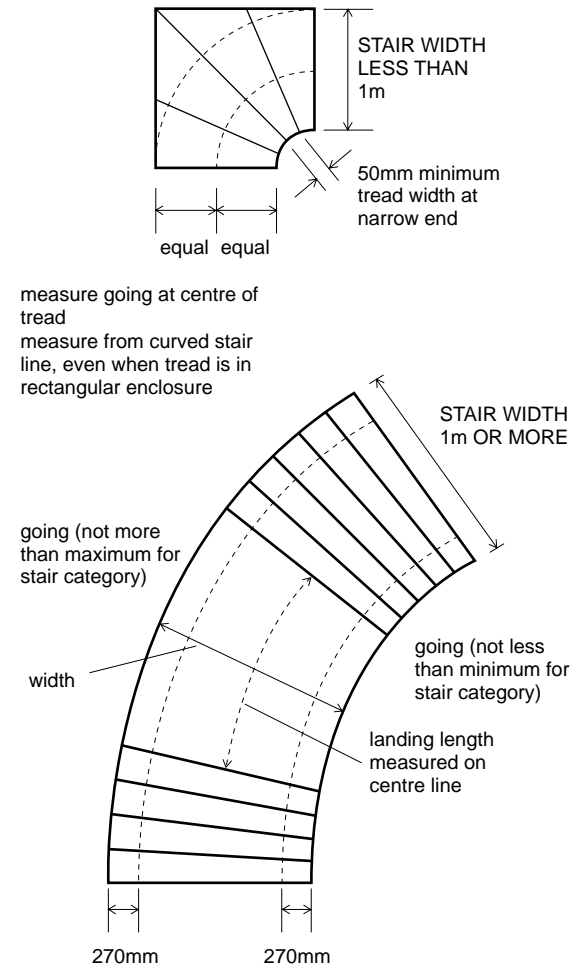

Section 3 – Ramps

Slope

3.1 The slope of a ramp shall not exceed 1 in 12 and shall be uniform throughout its length (see Diagram 3.1).

Width of ramps

3.2 The minimum widths for ramps shall be the same as those for flights (see paragraphs 2.9 and 2.10 and Table 2.2).

Length of ramps

3.3 The length of a ramp measured on plan shall not exceed 10 m.

Landings

3.4 Landings shall be level and be provided at the top and bottom of a ramp.

The width and going of a landing shall be not less than the width of the ramp. Part of a floor may be considered as a landing.

Obstruction of ramps and landings

3.5 Ramps shall be clear of obstructions and landings shall be clear of obstructions other than those described in paragraph 2.14.

Handrails

3.6 A ramp or a series of ramps with a total rise of more than 600 mm shall have a continuous handrail –

(a) on at least one side where they are 1 m wide or less;

(b) on both sides where they are more than 1 m wide; or

(c) on both sides where a ramp is divided into adjacent ramps in accordance with paragraphs 2.10 and 3.2.

Handrails shall be at a height measured vertically of between 900 mm and 1 m above the surface of the ramp, give firm support and allow a firm grip.

Handrails may form the top of guarding.

Handrails are not required where the side of a ramp is formed by fixed seating.

Headroom

3.7 Ramps and associated landings shall have a clear headroom of not less than 2 m over the length and width of the ramp.

Headroom is measured vertically from the slope of the ramp and the level of the landing.

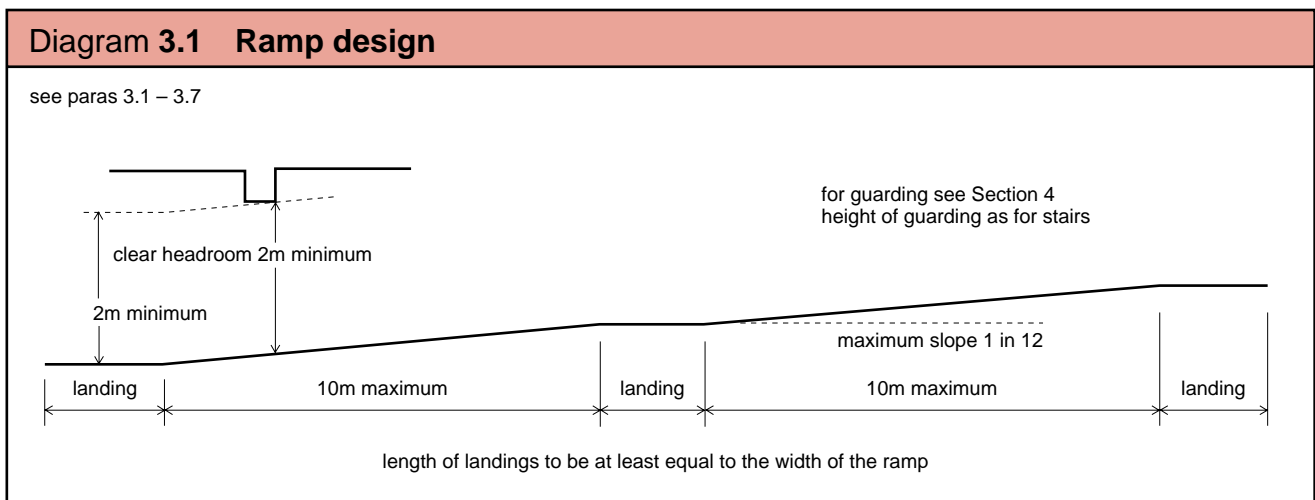

Section 4 – Guarding

Design of guarding

4.1 The design of guarding shall be such as to minimise the risk of people falling, and of rolling, sliding or slipping through gaps in a barrier.

A wall, glazing, parapet, balustrade or similar construction may serve as guarding.

A sunken area next to a building is an area adjoining the building and includes a light well, access to a basement and similar areas. Guarding shall be provided to that part of a sunken area which is within 3 m of the building.

4.2 The height of guarding shall be measured vertically from the level of a floor or landing, the surface of a ramp or the pitch line of a flight.

However, the top of a portion of any balustrade guarding a landing at the top of a flight or ramp may be continuous with, and at the same angle as, the top of a balustrade guarding that flight or ramp.

4.3 Guarding which is provided at the locations given in Table 4.1 column (1) shall be –

(a) of a height not less than that given in column (2); and

(b) capable of resisting the horizontal force given in column (3) applied at a height of 1100 mm irrespective of the actual height of the guarding (see Diagram 4.1).

Table 4.1 Minimum height and strength of guarding

Location of guarding (1)	Min height ⁺ (mm) (2)	Min horizontal force/metre run (kN/m) (3)
1 Dwellings		
(a) guarding a flight, ramp, landing or floor within a dwelling	900*	0.36
(b) guarding an external flight or ramp	900	0.74
(c) guarding a level for the purpose of maintenance	1100	0.36
(d) guarding not described in (a) to (c)	1100	0.74
2 Retail buildings		
(a) guarding a flight or ramp	900	1.50
(b) guarding a level for the purpose of maintenance	1100	0.36
(c) guarding not described in (a) or (b)	1100*	1.50
3 Other buildings		
(a) guarding a flight or ramp where crowd loading will not occur	900	0.74
(b) guarding a flight or ramp where crowd loading [†] will occur	900	3.00
(c) guarding not described in (b) where crowd loading [†] will occur	1100*	3.00
(d) guarding a floor immediately in front of fixed seating	800	1.50
(e) guarding a level for the purpose of maintenance	1100	0.36
(f) guarding not described in (a) to (e)	1100*	0.74

Notes

- + In the case of a flight or ramp the height shall be measured from the pitch line of a flight or the surface of a ramp.
- * This may be reduced to 800mm at openable windows or glazing at changes of level. The glazing may be designed to act as guarding, in which case separate guarding would not be required.
- † Crowd loading will occur in parts of buildings where people assemble in large numbers such as theatres, discotheques, cinemas, sports halls, assembly halls, shopping malls and similar areas.

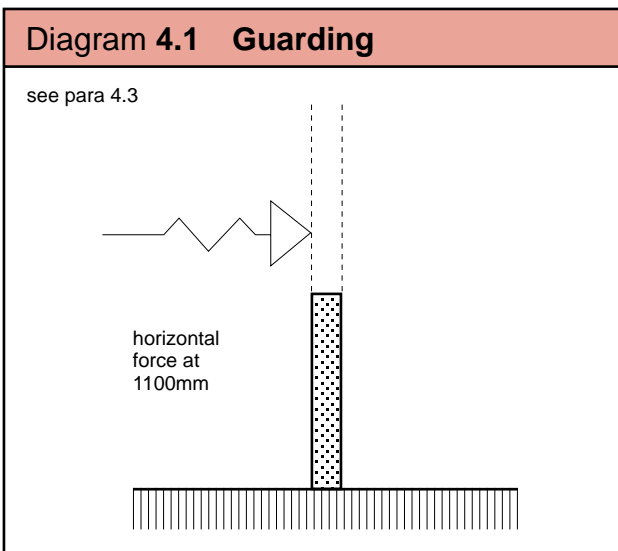

Infill panels

4.4 Where infill panels are provided they shall be designed and constructed in accordance with the relevant clauses of BS 6180:1999.

4.5 Where a building or part of a building is likely to be used by children under 5 years of age the guarding shall be constructed so that a 100 mm diameter sphere cannot pass through any opening in it other than a triangular opening formed by a tread, a rise and the bottom edge of the guarding if that bottom edge is not more than 50 mm above the pitch line. The guarding shall also be constructed so that a child cannot readily climb up it.

Section 5 – Vehicle loading bays

Loading bays

5.1 A loading bay shall be provided with at least one exit point from the lower level (preferably near the centre of the rear wall).

5.2 A wide loading bay (with space for 3 or more vehicles) shall be provided with at least –

(a) two exit points, one at each side; or

(b) an exit point and a refuge,

which people can use to avoid being struck or crushed by a vehicle (see Diagram 5.1).

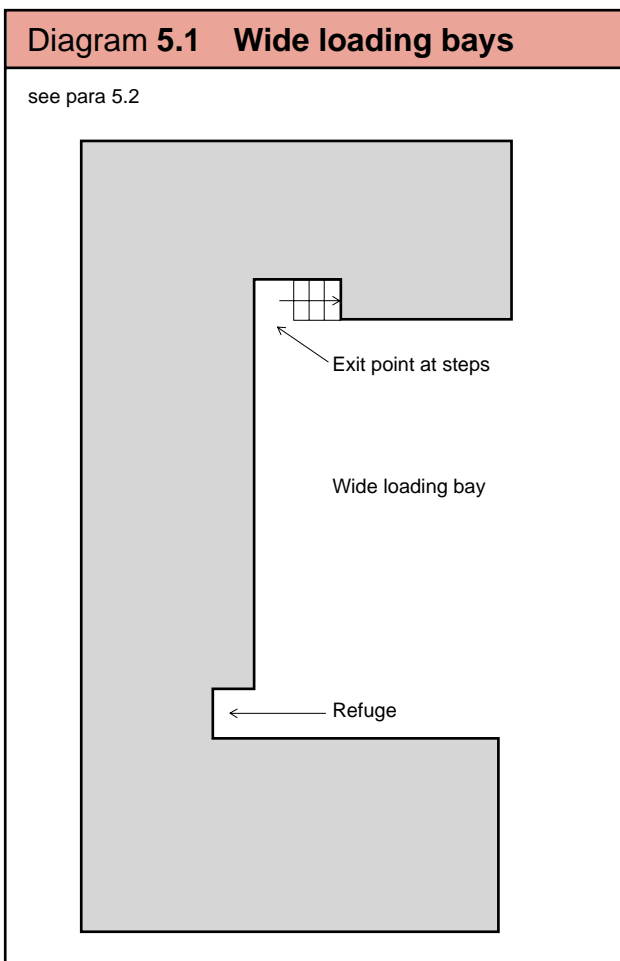

Section 6 – Protection against impact from and trapping by doors

6.1 A door or gate –

- (a)** across a main route of travel; and
- (b)** which can be pushed open from either side,

shall have a vision panel or panels unless the door or gate is low enough to see over (see Diagram 6.1).

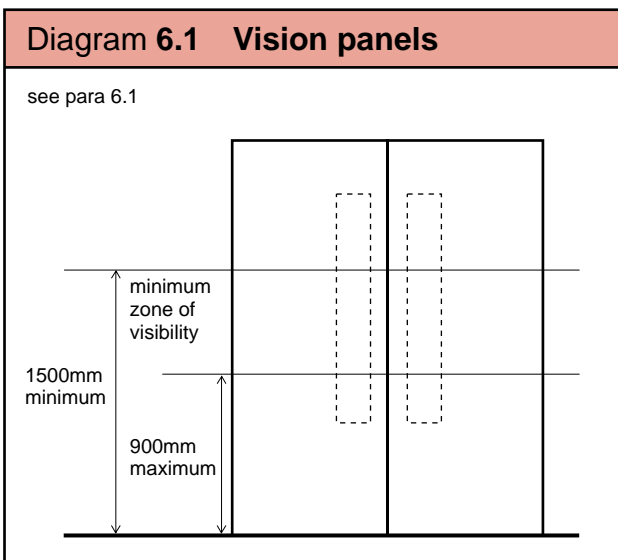

6.2 A door or gate that slides or opens upwards shall have a device to stop it falling in a way that may cause injury.

6.3 A power operated door or gate shall have –

(a) a pressure sensitive edge or other suitable device, which operates the power switch to prevent users being caught or trapped;

(b) a readily identifiable and accessible stop switch; and

(c) provision for manual or automatic opening in the event of a power failure.

Section 7 – Protection from collision with open windows, skylights or ventilators

7.1 Where any part of a window, skylight or ventilator, when open, could project more than 100 mm horizontally into a space less than 2 m above the ground or floor it shall be –

(a) fitted with a suitable device to restrict the projection in normal use to not more than 100 mm; or

(b) marked by a suitable feature such as –

(i) a barrier or rail not less than 1100 mm high;

(ii) a high relief surface; or

(iii) a landscape feature,

which extends to at least the maximum projection of the window, skylight or ventilator (see Diagram 7.1).

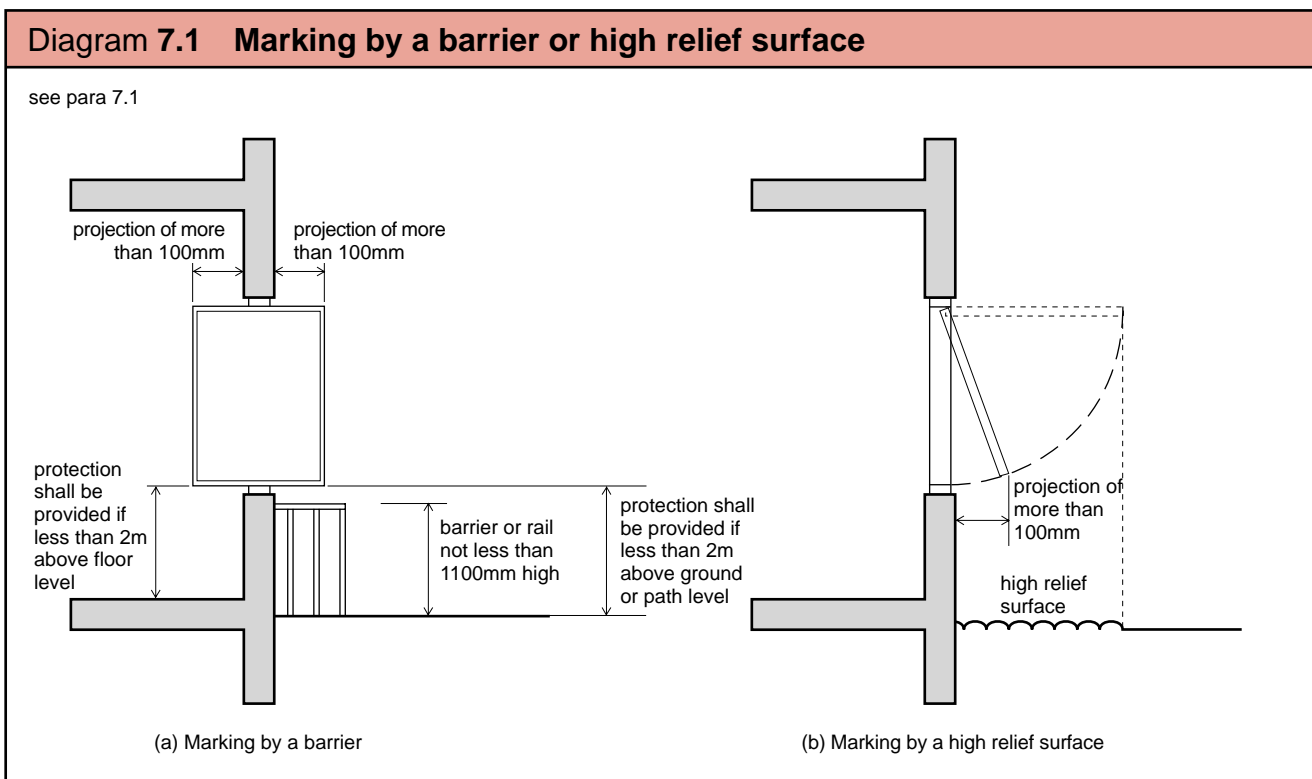

Appendix – Publications referred to

BS 6180: 1999 Code of practice for protective barriers in and about buildings